

KONICA MINOLTA

AccurioPress C5080
AccurioPress C5070

THE ACCURIOPRESS C5080 SERIES

REACH YOUR AMBITION



Giving Shape to Ideas

SMART FACTORY PRINTING

Imagine having just a single press that is good for everything: 2-sided banner printing, professional inline finishing, highest productivity, real-time automated quality adjustments, excellent print quality, and so much more. That's the AccurioPress C5080 series from Konica Minolta for you: our agile production colour press with features that enables you to expand your business into new markets and develop new revenue streams.

Enhanced Finishing

The optional in-line TU-510e 4-edge trimming unit cuts, creases and perforates to produce stunning full-bleed trimmed book jackets, imposed cards, business cards, coupons and more. Removing the need for off-line finishing means fewer operator touchpoints for faster and more efficient print runs.

A Single Engine Does It All

The AccurioPress C5080 series is a fully configured press to expand your business as you wish. You can print flat sheets, duplex long sheets of up to 900 mm, or directly finish prints inline with our extensive choice of finishing options to meet your clients' every need in on integrated production process.

Flawless Quality

Experience unparalleled print quality with our HDe toner, delivering stunning results on media up to 360 g/m². With ultra-sharp 3,600 x 2,400 dpi resolution and intelligent Colour Control checking 13 colours on the fly, you'll achieve exceptional consistency even during the fastest, longest print runs.

Streamline Your Workflow with Smart Assistance

Our production systems are engineered to maximize press uptime, enabling you to produce more in less time. With advanced assistance features designed for speed and quality, you can deliver high-value print products faster than ever. Tools like the Intelligent Quality Optimizer Unit and Intelligent Media Sensor ensure consistent, high-quality results for every job, with minimal user intervention – empowering you to work smarter and achieve exceptional outcomes effortlessly.



INNOVATIVE PRINT

RETHINK TECHNOLOGY

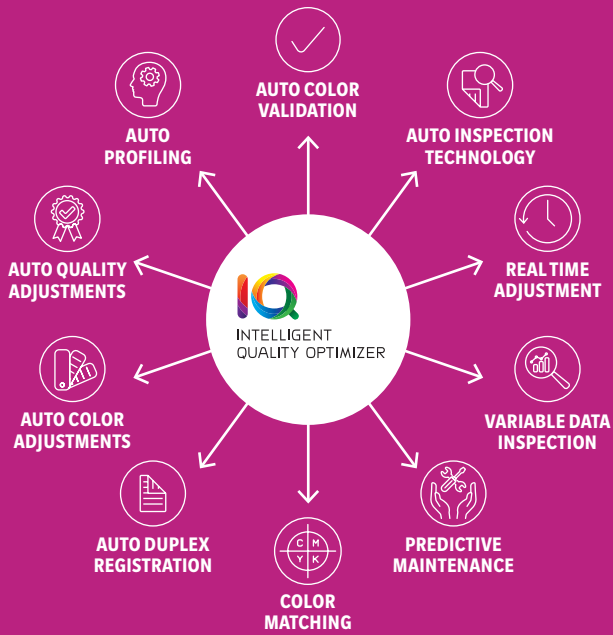

INTELLIGENT QUALITY OPTIMIZER

Intelligent Quality Optimizer

The IQ-601 Intelligent Quality Optimiser redefines printing with exceptional color accuracy, real-time adjustments, and automated workflows. Equipped with an inline spectrophotometer, it ensures precise color tones, improved front-to-back registration, and effortless operation – delivering superior results at the press of a button. Paired with the AI-101 Auto Inspection Unit, it enables advanced defect detection, variable data validation, and real-time quality assurance without requiring specialized training. Together, IQ-601 and AI-101 streamline processes, enhance quality stability, and maximize productivity, setting a new standard for high-performance printing.



S.E.A.D. X Image Processing

Konica Minolta's own advanced color processing technology of the fifth generation is called S.E.A.D. X which stands for "Screen-Enhancing Active Digital Process", and combines an array of technical innovations to guarantee truly exceptional color reproduction at top speed.

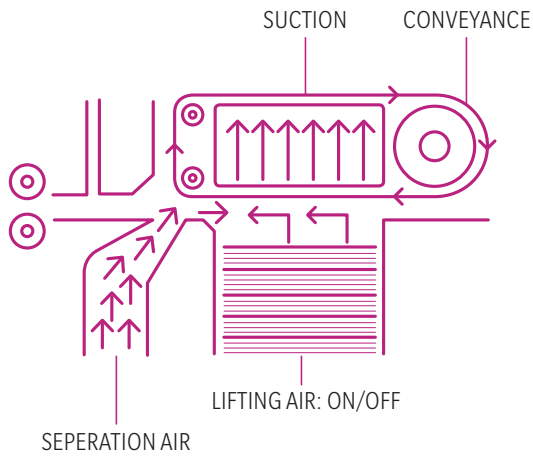

Vacuum paper feeding

It is essential for high-volume printers to feed each and every sheet smoothly and precisely through the digital press. To ensure this, Konica Minolta offers professional and intelligent paper feeding for all formats up to 900 mm length that builds upon proven concepts, including a combination of air separation of sheets and suction /vacuum feeding. This ensures smooth paper processing throughout the printing system. For efficient printing on offset pre-printed and coated stock as well as under high humidity conditions, an optional heating unit can be added to enhance this precise technology further.

Intelligent Media Sensor

The Intelligent Media Sensor IM-104 is a game-changer in automated print management! With six cutting-edge sensors, the IM-104 identifies paper type, weight, and size instantly, ensuring optimal print settings every time—no operator input needed. Say goodbye to manual adjustments and let the IM-104 handle it all. The IM-104 also features a purge tray, allowing production to keep running in case of paper jams or double feeds. For uninterrupted, unattended printing, this feature is invaluable. Plus, it detects mismatched paper settings during print production and stops the production to avoid any further complications down the line.

The Intelligent Media Sensor IM-105 adds precision and perfection in every print. The IM-105 measures the paper size of the substrates and detects even the slightest variations in paper cutting size and, together with the Intelligent Quality Optimizer IQ-601, automatically adjusts image positioning to eliminate front/back alignment errors. Enjoy flawless results with less manual oversight, ensuring professional quality and consistency with every print run.

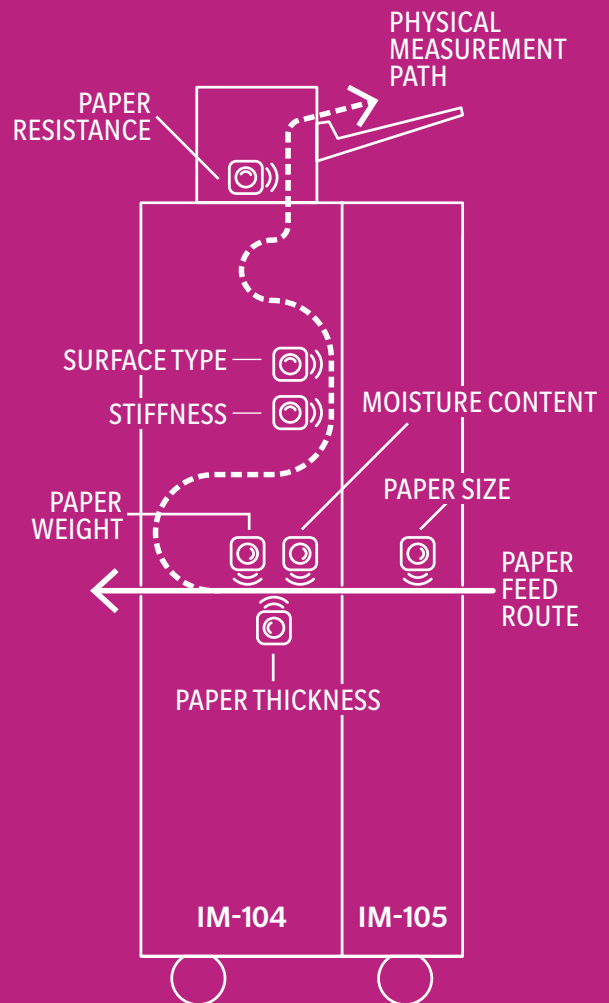





STATE-OF-THE-ART- PRINT-SERVER RETHINK PRODUCTION PRINTING

ACCURIOIMAGE IC-613

The Konica Minolta IC-613 print controller comes with powerful workflow benefits – including 2,400 x 3,600 equiv. dpi printing at full rated engine speed, highspeed RIP processing, enhanced accuracy in color reproduction, various color management functions as well as full compatibility with print engine on-board job control and editing functions.

THE IC-421 INTERNAL FIERY IMAGE CONTROLLER

As the embedded Fiery® controller alternative, the IC-421 offers a combination of affordability, versatile colour management and PCL support plus a wide range of security features. It helps improve the ease of use of AccurioPress systems, and simplifies workflows so that our digital colour presses deliver truly professional print results, making any configuration an ideal business solution for your company's printing facilities.

THE IC-321 FIERY IMAGE CONTROLLER

Providing advanced job management and workflow automation, the Fiery® IC-321 reduces labour costs, cuts turnaround times, and minimizes errors as well as waste. The instant visual preview and advanced make ready capabilities streamline job layouts. Support of industry-leading variable data printing (VDP) formats facilitates the profitable production of personalized short-run jobs.



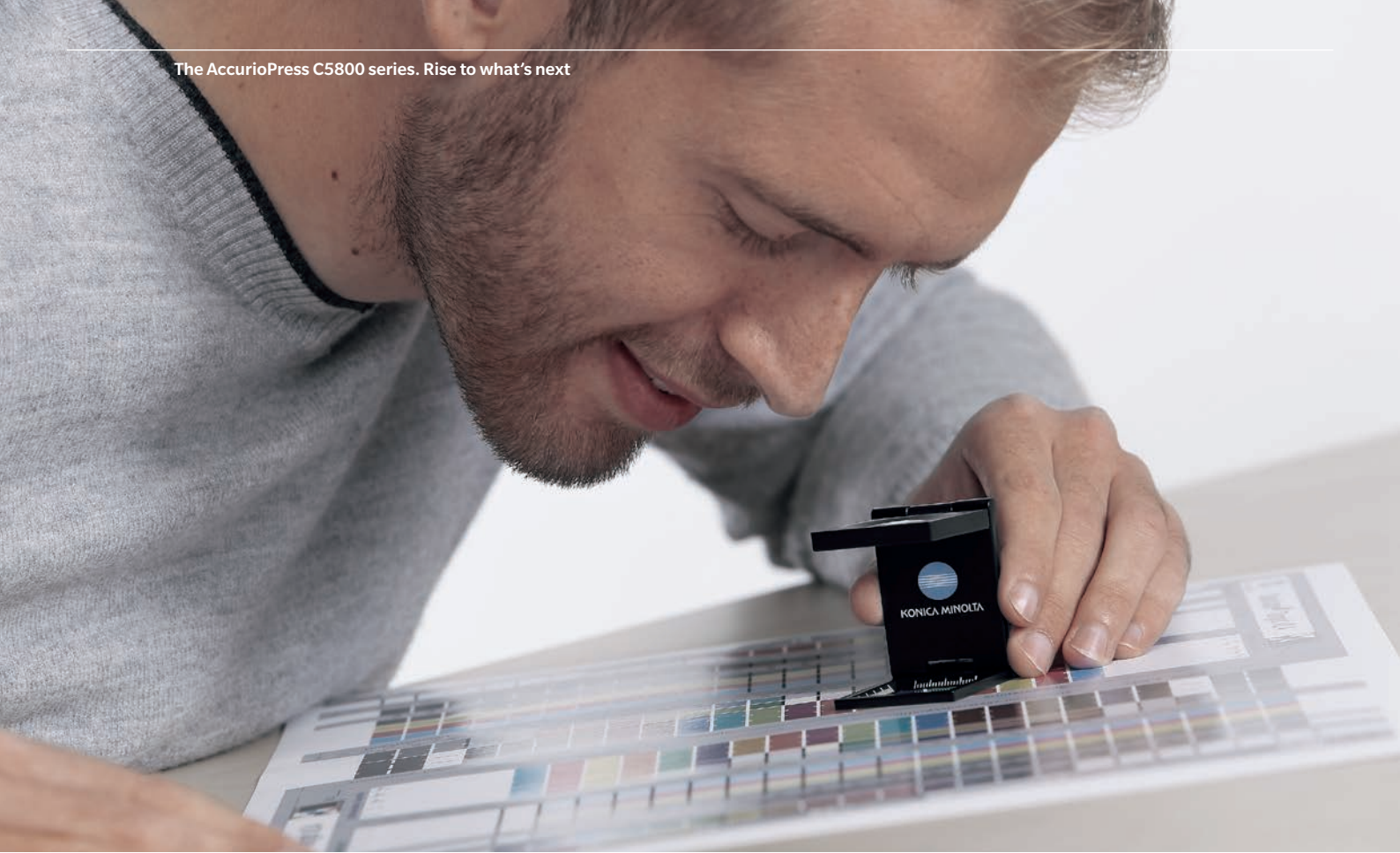

STREAMLINE YOUR PRODUCTION

RETHINK YOUR WORKFLOW

Evolving from our expertise in precision technologies and more than 80 years of experience in the printing and imaging industries, AccurioPro reflects our commitment to developing market-shaping technology with functionality that enables your business to grow. AccurioPro, Konica Minolta's suite of digital solutions for professional printing, is one of the industry's most versatile and powerful tools to optimise print production operations and workflows.

For all printing companies looking to integrate their printing as well as businesses that use digital printing to produce their own in-house publications and promotional materials, AccurioPro boosts speed and

efficiency, expands capabilities and services, and reduces the need for operational manpower – all of which will help improve your profitability.

The comprehensive suite of features that AccurioPro offers includes centralised management, software for automated workflow processing, color management, seamless integration of different printing technologies and full connectivity of all Konica Minolta printing systems used from input to output.

AccurioPro POSSIBILITIES

RETHINK YOUR WORKFLOW

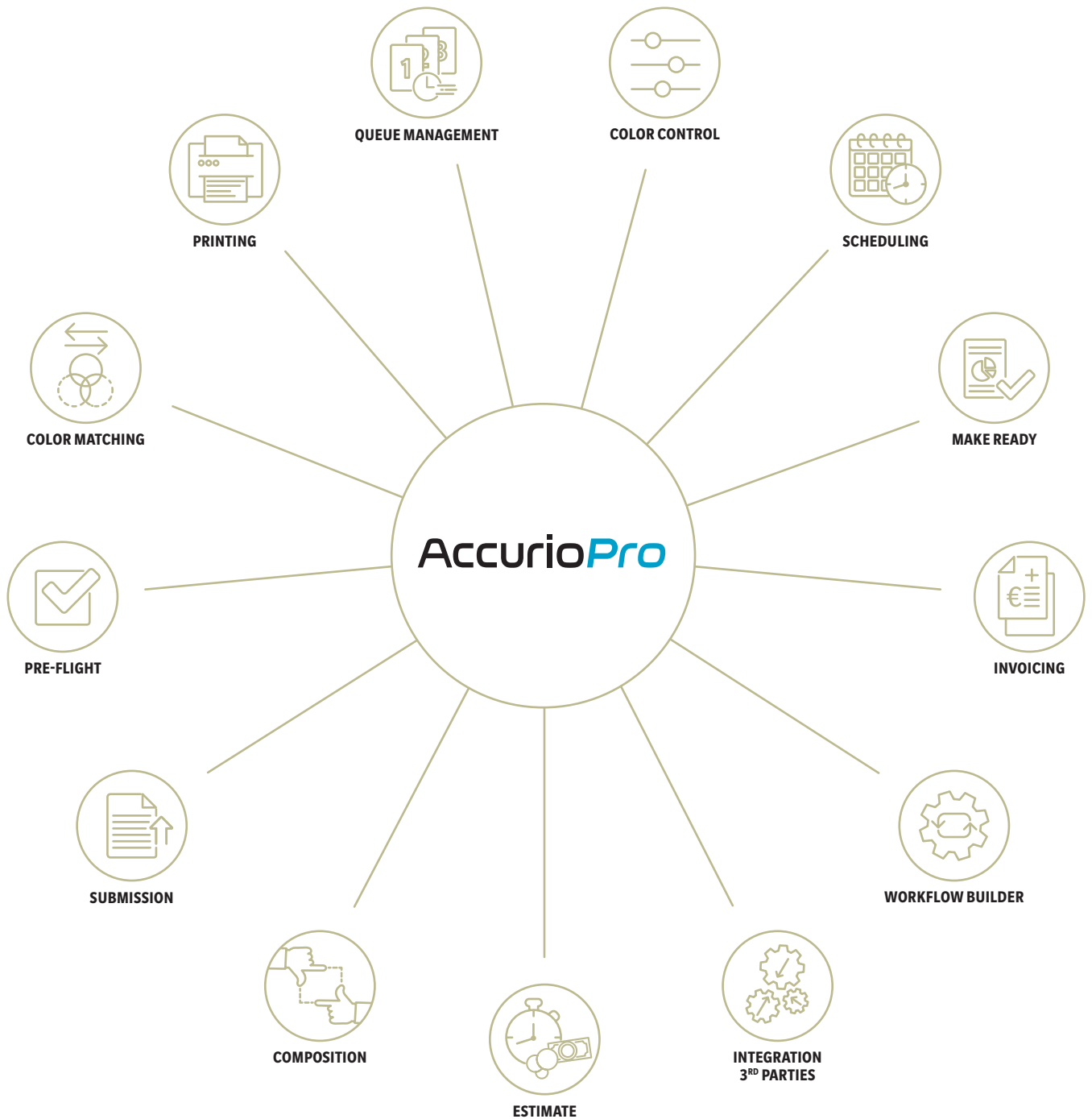

YOUR ADVANTAGES WITH THE AccurioPress C5080/C5070

RETHINK PRODUCTION PRINTING

DURABLE PERFORMANCE

AccurioPress C5080

- Up to 81 A4 colour pages per minute
- Up to 45 A3 colour pages per minute
- Peak Volume of up to 864,000 A4 images per month
- Lifetime up to 6 million A4 images or 5 years

AccurioPress C5070

- Up to 71 A4 colour pages per minute
- Up to 39 A3 colour pages per minute
- Peak Volume of up to 758,000 A4 images per month
- Lifetime up to 6 million A4 images or 5 years

READY-MADE PRINT PRODUCTS*

- 50-sheet booklet making with front trimming and optional creasing, slitting and spine corner forming
- 100-sheet stapling with cutting mechanism
- Automated inline business card and postcard cutting
- Full bleed banners, A3 and A4 posters

GEARED-UP FINISHING*

- Multi (GBC) punching and 2- & 4-hole punching
- 6 different types of folding
- 3rd-party Products
- Large-capacity stacking
- 2 Perforations in feed direction, 5 Perforations in Cross feed direction
- Up to 5 Creases downwards or upwards

SIMPLY EFFICIENT

- Automated engine linearisation
- Automated duplex registration
- Automated profiling
- Real-time adjustments
- Purge function

PERFECT IMAGE QUALITY

- S.E.A.D. V technology and 3,600 x 2,400 dpi x 8 bit resolution
- Simitri HDe toner technology
- Image density control technology

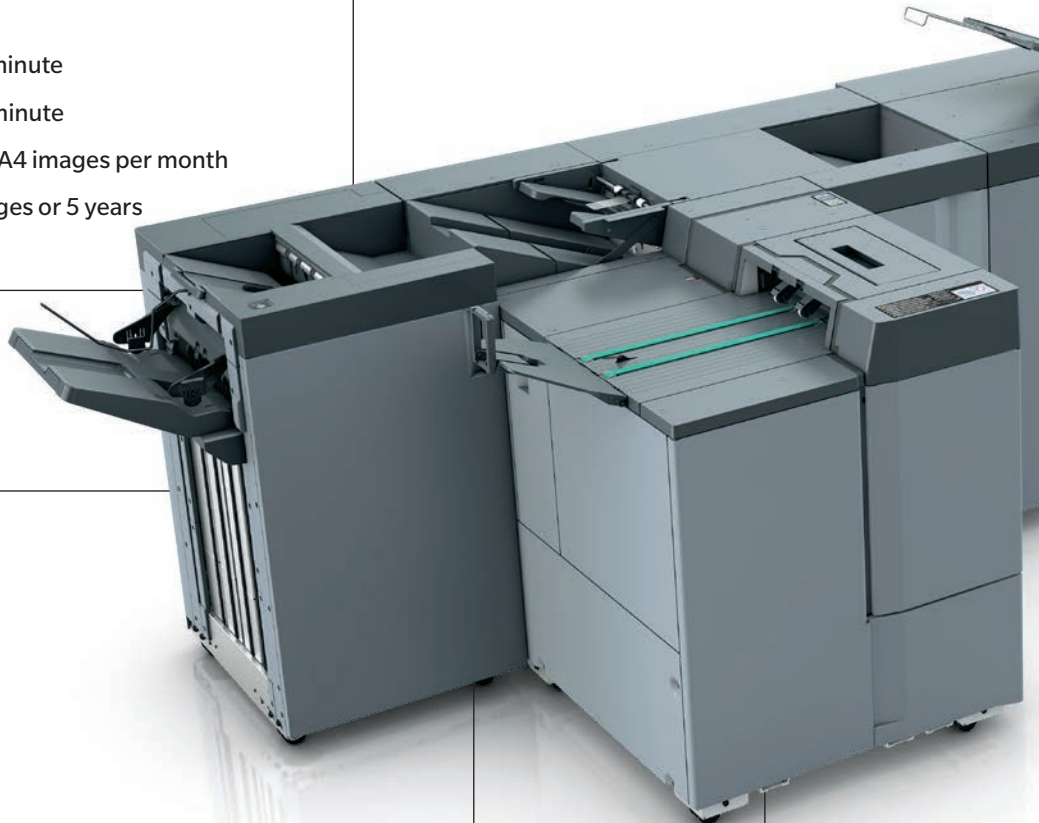

HIGHEST RELIABILITY

- Long-life platform, long-lasting parts and consumables
- Accurate front to back registration
- Fusing-rolling mechanism

HIGH-END PRINT CONTROL*

- Flexible choice of controller technology: Fiery® or proprietary Konica Minolta AccurioImage Controller
- Integration into hybrid workflows

EASE OF USE

- Simple paper catalogue settings
- Operator Replaceable Unit Management
- Auto Inspection Technology

SENSOR MEASURING*

- Detects and prevents multi-feed issues for greater production reliability
- Identifies media size before printing to reduce errors
- Includes a purge tray to support smooth, uninterrupted operation
- Enhances overall efficiency through precise, automated media handling

SOPHISTICATED MEDIA HANDLING*

- Automatic media recognition
- Air suction feeding technology
- Up to 11 paper trays
- Long sheet printing of up to 1300 mm (simplex), 900 mm (duplex)

INTELLIGENT QUALITY OPTIMISER*

- Ensures consistent, superior output through high-performing print profiles
- Uses AIT paper path and automatic sheet size detection for dependable accuracy
- Enables proofless inspection to identify deviations in real time
- Supports flawless, efficient production with minimal operator intervention

COMPREHENSIVE MEDIA PROCESSING

- Up to 360 g/m² paper weight in simplex and duplex
- Optional media sensor estimates paper weight and type
- Envelope print function as standard
- Support for embossed paper
- Optional inter-cooler curl eliminator



FINISHING & FUNCTIONS



Letter fold



2/4 hole Punching



Two-point stapling



Corner stapling



Stacking



Booklet



Trimming

Open stacker
OT-512



Staple finisher
FS-532m



Booklet making unit
SD-513



Stacking unit
LS-507



Folding and punching unit
FD-503



Booklet making unit
SD-506



Trimming unit
TU-510e



Booklet making unit
Plockmatic SD-450e/435e



Multi punching unit
GBC Punch G3



Ring binding unit
GBC Wire G1































Cold Lamination unit
GBC Laminator CL-401



Multi purpose stacker
Plockmatic MPS-XL



	 Creasing	 Perforation	 Slitting	 Square-folding	 Multi Letter fold-In	 Post Insertion	 Wire-binding	 Multi-punching	 Lamination	
										ENTRY
										
										
										MID
										
										
										
										
										

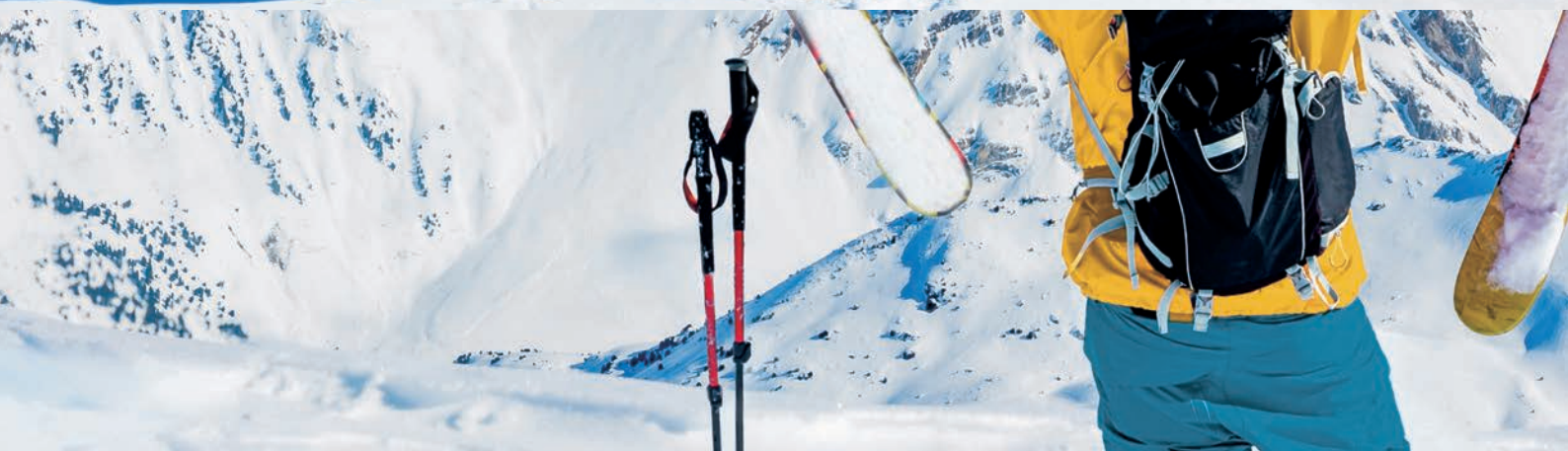



10 GOOD REASONS FOR AccurioPress C5080 SERIES



1. SIMPLY EFFICIENT

with Media Detection Sensor, Intelligent Quality Care and many unique inline finishing options.



2. PERFECT IMAGE QUALITY

with Konica Minolta's very own Imaging Technology and Toner development.



3. SEAMLESS INTEGRATION

into Konica Minolta's application portfolio.

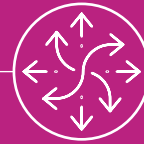

4. VERSATILE CONFIGURATIONS

over 700 possibilities to configure your own press.



5. ENHANCE YOUR RANGE OF PRINT OFFERINGS

and fulfill today's demands for versatile and creative print products.



6. OUTSTANDING PAPER COMPATIBILITY

Media up to 360 g/m². Excellent versatility with class leading banner printing, envelop printing and texture printing capabilities.



7. SHORT TURNAROUNDS

with automated quality control and inspection on the fly.



8. LOW LEARNING CURVES

Precise colour matching, even for novice operators, avoids or at least minimises learning curves



9. BENEFIT FROM GREAT BUILT-IN TECHNOLOGIES

e.g. the latest screening and registration technologies.



10. HIGH OUTPUT EVEN WITHOUT SKILLS

by improved technologies.





TAKE LEADERSHIP AND RESPONSIBILITY

RETHINK TOMORROW'S BUSINESS

MADE FOR YOUR BUSINESS

Commercial printers

Growing your business and getting the maximum out of your investment is our production printing portfolio promises. High speed, high productivity and high uptime help you achieve the shortest turnaround times. Great media flexibility – with stocks of up to 360 g/m² – further enhance the offerings of your print shop. Quality issues are also a thing of the past, as these presses offer a wide range of tools that control and adjust themselves.

CRDs

Our production printing portfolio supports a high degree of automation and also ensure high-level quality. Professional inline finishing produces ready-made print products at the click of a finger. While versatile media flexibility and high productivity make our cutting-edge technologies solid and lucrative investment for the future.

SUSTAINABILITY MEASURES FOR OUR PRODUCTION PRINTERS

Konica Minolta aims to reduce CO₂ emissions throughout the product lifecycle to net zero by 2050. Further, we aim to make our products from more than 90% circulated resources (recycled materials and biomaterials) by 2050. Our activities also include our customers, who we want to support in reducing their environmental impact as much as possible and achieving their sustainability goals.

An advantage of the digital printing process is the ability to print quickly and flexibly on demand, i.e. to produce only the print quantities that are actually required. Konica Minolta considers its environmental impact at every stage of the product life cycle and takes measures to reduce it.

This begins with manufacturing: all Konica Minolta factories are working under a certified ISO14001 Environmental Management System, for example, and all production printing devices of our current fleet sold in Europe are produced in factories using 100% renewable energies. Our achievements have received the Japan Federation of Printing Industries Green Printing certification.

In terms of product design, we are taking measures to reduce the use of primary resources. For example, we have developed lighter systems that weigh up to 25% less than

previous models. We are also focusing on the increased use of recycled materials: our production printers incorporate up to 36% recycled plastic, while toner bottles are made with up to 60% recycled plastics.

We have also implemented measures to reduce energy consumption during product use. Our polymerised toners can be fixed at lower temperatures, e.g. the Simitri® V toner has a fixing temperature that is 15 degrees Celsius lower.

As far as the disposal phase is concerned, our toners ensure a very high level of deinkability, which has also been certified by INGEDE. This means that the printed paper can be easily recycled, saving energy, raw materials and reducing water pollution. We also offer a high-quality returns and recycling service with the Clean Planet Program. We collect and safely dispose of used toner cartridges and bottles, photoconductor drums, and other consumables and recycle them. As a result, up to 87.3% of waste is turned into secondary raw materials. This helps reduce waste, increase efficiency, and preserve the earth's natural resources.

With our digital printing systems, Konica Minolta can therefore help our customers to move away from large-scale analogue printing and use less resources – such as inks, substrates and electricity, and also reduce waste and CO₂ emissions.

CONTROLLER AND OPTIONS

RETHINK THE NEEDS

FIERY IMAGE CONTROLLER IC-321

Architecture	External
OS	Windows
CPU	Intel® i3-12100
RAM std	8 GB
HDD	SSD Boot drive + 1TB
Page-description language	CPSI 3020; APPE 6.0; Adobe® PostScript® Levels 1, 2, 3; Adobe PDF, PDF/X-1a, 3, and 4; Optimised PostScript® and PDF; Enhanced PCL6/PCL5; EPS, TIFF, JPEG (via Hot Folders)

FIERY IMAGE CONTROLLER IC-421

Architecture	Internal
OS	Linux
CPU	Intel® G7400E
RAM std	8 GB
HDD	500 GB SSD
Page-description language	CPSI 3020; APPE 6.0; Adobe® PostScript® Levels 1, 2, 3; Adobe PDF, PDF/X-1a, 3, and 4; Optimised PostScript® and PDF; Enhanced PCL6/PCL5; EPS, TIFF, JPEG (via Hot Folders)

ACCURIOIMAGE CONTROLLER IC-613

Architecture	Internal
OS	Linux
CPU	Intel® i5-10500
RAM std	2 TB
HDD	1 TB
Page-description language	Adobe® PostScript®3 (CPSI3022); PDF direct print (PDF Ver. 2.0); APPE (Ver. 6.2) (The UK-225 is required.); PDF1.3 to 2.0; PDF/X-1a, PDF/X-3, PDF/X-4, PDF/VT-3; TIFF direct print (TIFF Ver. 6 compliance); PPML (Ver. 2.2); PCL 5C compatible; PCL XL (PCL6 Ver. 3) compatible

OPTIONS

AccurioImage Controller	IC-613
EFI external Controller	IC-321
EFI internal Controller	IC-421
Paper Feeding Unit	PF-712
Paper Feeding Unit	PF-812
Dehumidifier Heater	HT-506
Multi Bypass Tray	MB-511
Dehumidifier Heater	LU-208
Large Capacity Feeding Unit	LU-208XL
Dehumidifier Heater	HT-518
Humidifier	MK-746
Multi bypass feeding	MB-509
Auto Inspection Kit	RU-518m
Humidifier	HM-103
Intelligent Quality Optimizer	IQ-601
Auto Inspection Kit	AI-101
Intelligent Media Sensor	IM-101
Intelligent Media Sensor	IM-104
Intelligent Media Sensor (paper size)	IM-105
Envelop Fusing Unit	EF-111
Output Tray Unit	OT-512
Long Sheet Kit (Input)	MK-760
Long Sheet Kit (Output)	MK-761
3rd party Interface	MK-737
Relay Unit	RU-510
Stapling Unit	FS-532m
Saddle Stitcher Kit	SD-510
Punch Kit	PK-525
Mount Kit	MK-732
Post Inserter Kit	PI-502
Press and Trim Kit	PT-220
Corner Forming Kit	SF-204
Folding and Punching Unit	FD-503
Booklet Making Unit	SD-506
Booklet Making Unit	SD-513
Folding Kit	FD-504
Trimmer Kit	TU-503
Creaser Kit	CR-101
Stacking Unit	LS-507
Stacking Unit	LC-502
Trimmer Unit	TU-510e
Creaser kit (downwards)	CR-102
Creaser kit (Upwards)	CR-103
Trimmer Kit	TU-504
Banner Kit	MK-764
Business Card Kit	JS-507
Perforation Kit Horizontal	PE-101
Perforation Kit Vertical	PE-102
Scrap Ejection Kit	MK-765
GBC Punch Unit	GBC Punch G3
GBC Binding Unit	GBC Binder G1
GBC Lamination Unit	GBC Laminator CL-401
Booklet Making Unit	SD-435e/450e
Banner Stacking Unit	Plockmatic MPS-XL





KONICA MINOLTA

TECHNICAL SPECIFICATIONS

RETHINK PRODUCTION PRINTING

SYSTEM SPECIFICATIONS

Resolution	3,600 x 2,400 dpi x 8 bit
Paper weight	62 – 360 g/m ²
Duplex Unit	non stack type: 62 – 300 g/m ²
Paper sizes	330.2 x 487.7 mm 330.2 x 900 mm (max.duplex) 330.2 x 1300 mm (max. simplex)
Paper input	Max.: 15,390 sheets
Recommended environmental conditions	21 – 26° C temperature; 40 – 60 % relative humidity (Deviations may affect the specifications)
Non printable area	Leading/Trailing edge: ≤4 mm Right/Left edge: ≤3 mm Trailing edge: ≤6 mm for thick paper (g/m ² or more)
Image registration	+/- 0,6 mm
Dimension (WxDxH)	800 x 903 x 1076 mm
Unit weight	312 kg

PRODUCTIVITY

AccurioPress C5080	
A4 – max. per minute	81 ppm
A3 – max. per minute	45 ppm
SRA3 – max. per minute	36 ppm
A4 – max. per hour	4,416 pph
AccurioPress C5070	
A4 – max. per minute	71 ppm
A3 – max. per minute	39 ppm
SRA3 – max. per minute	38 ppm
A4 – max. per hour	3,846 pph

- All specifications refer to A4-size paper of 80 g/m² quality.
- The support and availability of the listed specifications and functionalities varies depending on operating systems, applications and network protocols as well as network and system configurations.
- Product illustrations contain optional accessories.
- Specifications and accessories are based on the information available at the time of printing and are subject to change without notice.
- All brand and product names may be registered trademarks or trademarks of their respective holders and are hereby acknowledged.
- Our showrooms can be used to test print speed and performance with specific media formats and materials.

More information about
the AccurioPress C5080



Take a Tour – Explore our
Virtual Showroom

